



MAGNUM





Seit dem Jahr 2004 stehen vier Generationen TECHART Magnum
für unübertroffene Individualisierung auf Basis der Porsche Cayenne Modelle.
Für unverwechselbares Design, atemberaubende Performance und höchste Qualität.

Willkommen beim Maß der Dinge.

Der TECHART Magnum. Premium-Individualisierung für die vierte Cayenne Generation.

Since 2004, four TECHART Magnum Generations have been synonymous
with unsurpassed Premium Refinement based on the Porsche Cayenne models.
Renowned for unmistakable design, breathtaking performance and superior quality

Welcome to the Measure of Things.

The TECHART Magnum. Premium Refinement for the 4th Cayenne Generation.







Aerodynamik

Aerodynamics

Aerodynamik Paket »Magnum«

TECHART Magnum Frontverkleidung mit integrierten Luftführungen zur effektiven Anströmung der Wasser- und Ladeluftkühler sowie zur verbesserten Hitzeabfuhr an der Bremsanlage. Inklusive Frontgrill, Nebelscheinwerfereinheit sowie Airblades links und rechts mit Lufteinlass und Aufnahme für TECHART Tagfahrlichtsystem.

TECHART Magnum Radhausverbreiterungen vorn und hinten

TECHART Magnum Seitenschwellerverkleidungen

TECHART Magnum Heckverkleidung mit Diffusor

Multifunktionales TECHART Tagfahrlichtsystem inkl. Steuergerät und Kabelsatz

Aerokit »Magnum«

TECHART Magnum front apron with integrated air intakes for effective cooling air flow to the water cooler and intercoolers as well as for an optimum heat dissipation of the braking system. Front apron includes front grill, auxiliary fog light unit and Airblades with air intakes and gear for TECHART daytime running light system.

TECHART Magnum wheel arch extensions at front and rear

TECHART Magnum side skirt panels

TECHART Magnum Rear apron with diffusor

TECHART Daytime Running Light System including electronic managment unit and cable harness

058.100.052.009

Aerodynamik Zusatzoptionen

Aero-Motorhaube aus Kohlefaser
(Varianten: in Wagenfarbe lackiert, in Sichtcarbon hochglänzend oder in Sichtcarbon matt)
mit integrierten Lufteinlässen (mehrere Designvarianten wählbar/kombinierbar)

Dachspoiler (Varianten: Flügelprofil in Wagenfarbe lackiert, in Sichtcarbon hochglänzend oder in Sichtcarbon matt)

Zierblenden für Scheinwerfer

Zierblenden für Heckleuchten

Heckspoilerblende

Zierblenden für Außenspiegel, in Kohlefaser

Additional Aerokit Options

Aero Engine Lid, carbon fiber
(Variants: painted in body color, high-gloss or matt finished carbon fiber structure) with integrated air intakes (different design variants of the air intakes can be selected/combined)

Roof Spoiler (Variants: wing profile painted in body color, high-gloss or matt finished carbon fiber structure)

Headlight Trims

Taillight Trims

Rear Spoiler Panel

Side Mirror Trims, carbon fiber

058.121.199.009

058.100.654.009

058.100.202.009

058.100.602.009

058.100.702.009

058.121.322.[...]

Cayenne
Cayenne Diesel / S Diesel
Cayenne S
Cayenne S E-Hybrid
Cayenne GTS
Cayenne Turbo / Turbo S

<input type="checkbox"/>	<input type="checkbox"/>	<input type="checkbox"/>	<input type="checkbox"/>	<input type="checkbox"/>	<input type="checkbox"/>
<input type="checkbox"/>	<input type="checkbox"/>	<input type="checkbox"/>	<input type="checkbox"/>	<input type="checkbox"/>	<input type="checkbox"/>
<input type="checkbox"/>	<input type="checkbox"/>	<input type="checkbox"/>	<input type="checkbox"/>	<input type="checkbox"/>	<input type="checkbox"/>
<input type="checkbox"/>	<input type="checkbox"/>	<input type="checkbox"/>	<input type="checkbox"/>	<input type="checkbox"/>	<input type="checkbox"/>
<input type="checkbox"/>	<input type="checkbox"/>	<input type="checkbox"/>	<input type="checkbox"/>	<input type="checkbox"/>	<input type="checkbox"/>
<input type="checkbox"/>	<input type="checkbox"/>	<input type="checkbox"/>	<input type="checkbox"/>	<input type="checkbox"/>	<input type="checkbox"/>
<input type="checkbox"/>	<input type="checkbox"/>	<input type="checkbox"/>	<input type="checkbox"/>	<input type="checkbox"/>	<input type="checkbox"/>
<input type="checkbox"/>	<input type="checkbox"/>	<input type="checkbox"/>	<input type="checkbox"/>	<input type="checkbox"/>	<input type="checkbox"/>
<input type="checkbox"/>	<input type="checkbox"/>	<input type="checkbox"/>	<input type="checkbox"/>	<input type="checkbox"/>	<input type="checkbox"/>
<input type="checkbox"/>	<input type="checkbox"/>	<input type="checkbox"/>	<input type="checkbox"/>	<input type="checkbox"/>	<input type="checkbox"/>
<input type="checkbox"/>	<input type="checkbox"/>	<input type="checkbox"/>	<input type="checkbox"/>	<input type="checkbox"/>	<input type="checkbox"/>
<input type="checkbox"/>	<input type="checkbox"/>	<input type="checkbox"/>	<input type="checkbox"/>	<input type="checkbox"/>	<input type="checkbox"/>
<input type="checkbox"/>	<input type="checkbox"/>	<input type="checkbox"/>	<input type="checkbox"/>	<input type="checkbox"/>	<input type="checkbox"/>





Lackierung

Paint

<p>Individuellackierung in Sonderfarbe, glänzend</p>	<p>Individual Paint to Sample custom color, glossy</p>	058.108.010.998	<input type="checkbox"/> <input type="checkbox"/> <input type="checkbox"/> <input type="checkbox"/> <input type="checkbox"/> <input type="checkbox"/>
<p>Individuellackierung in Sonderfarbe, matt</p>	<p>Individual Paint to Sample custom color, matt</p>	058.108.011.998	<input type="checkbox"/> <input type="checkbox"/> <input type="checkbox"/> <input type="checkbox"/> <input type="checkbox"/> <input type="checkbox"/>
<p>Individuellackierung in Effektfarbe, matt oder glänzend</p>	<p>Individual Paint to Sample special effect paint, matt or glossy</p>	058.108.012.998	<input type="checkbox"/> <input type="checkbox"/> <input type="checkbox"/> <input type="checkbox"/> <input type="checkbox"/> <input type="checkbox"/>

Cayenne
Cayenne Diesel / S Diesel
Cayenne S
Cayenne S E-Hybrid
Cayenne GTS
Cayenne Turbo / Turbo S

Das TECHART Magnum Aerokit ist auch für alle Porsche Cayenne Modelle mit Anhängenzugvorrichtung ab Werk sowie für US-Fahrzeugausführungen erhältlich. Zusätzlich haben Sie die Möglichkeit, Bestandteile des TECHART Magnum Aerokits nach Ihren Wünschen zu variieren. Zum Beispiel sind Grills, Airblades und weitere Bestandteile in Wunschfarbe lackiert oder Schwarz matt erhältlich. Das Tagfahrlichtsystem wird wahlweise in elegantem Chrom oder sportlichem Schwarz ausgeführt. Die Nebelscheinwerfer stehen in Halogen- oder LED-Technologie zur Verfügung. All diese Wahlmöglichkeiten sorgen dafür, dass Ihr TECHART Magnum so aussieht, wie Sie es sich wünschen. Mit sportlichen Kontrasten oder elegant Ton in Ton. Ihr TECHART Kundenberater informiert Sie gerne über alle TECHART Magnum Varianten und berät Sie individuell.

The TECHART Magnum Aerokit is also available for all Porsche Cayenne models with towbar system as well as for all US-versions. For maximum individualization opportunities, parts of the TECHART Magnum Aerokit can be varied and combined according to your preferences. Such as the grills, airblades and other styling parts which can be ordered in custom color or in matt black finish. The Daytime Running Light System is available in Chrome or Black in order to provide a seamless elegant or sport-focused look. The fog lights are available in Halogen or LED technology to fit the light color or the base vehicle's headlights. These are just a few examples of the diversity of the new TECHART Magnum Program, providing all options to make your Cayenne model individually yours. Your sales manager at TECHART will be happy to give any assistance.

Video ansehen



Watch video

Hörbares Fahrvergnügen.
TECHART Sportabgasanlagen mit Klappensteuerung.

Audible driving pleasure.
TECHART valve-controlled sport exhaust systems.





Aerodynamik

Aerodynamics

Aerodynamik Paket »Magnum Sport«

Ausstattungspaket "Magnum Sport" in glänzend
Ausstattungspaket "Magnum Sport" in matt

Lieferumfang: Splitter (3-teilig) Carbon, Finnen Air-
blade (2-teilig) Carbon, Schachtblende Verbreiterung
vorn in Carbon, Türzierleisten in Carbon und Schrift-
zug "Magnum Sport", Diffusor (1-teilig) in Carbon,
Schachtblende Heckschürze in Carbon, Magnum
Sport Schriftzug.

Hinweis: Nur in Verbindung mit Magnum-Kit
(058.100.052.009)

Aerokit »Magnum Sport«

Ausstattungspaket "Magnum Sport" in glänzend
Ausstattungspaket "Magnum Sport" in matt

Scope of delivery: Splitter (3 parts) carbon, Fins air-
blade (2 parts) carbon, Shaft panel front extension
in carbon, door trims in carbon and lettering
"Magnum Sport", Diffusor (1 part) in carbon, Shaft
panel rear apron in carbon, Magnum Sport logo.

Notice: Only in combination with Magnum-Kit
(058.100.052.009)

«

058.100.097.009G
058.100.097.009

Cayenne
Cayenne Diesel / S Diesel
Cayenne S
Cayenne S E-Hybrid
Cayenne GTS
Cayenne Turbo / Turbo S

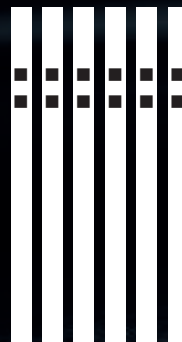

Der TECHART Magnum Sport ist die sportbetonte Variante des TECHART Magnum auf Basis der Porsche Cayenne Modelle. Das Sondermodell verfügt über ein erweitertes Aerodynamikpaket mit neuen Bestandteilen aus Sichtcarbon.

Ein neuer dreiteiliger Frontsplitter mit besonders dynamischer Kontur sowie zusätzliche Finnen in den großen Lufteinlässen erregen Aufsehen an der Frontpartie des Magnum Sport. Rundstrecken-Flair erzeugen die neuen Luftauslässe in den vorderen verbreiterten Radhäusern sowie auf beiden Seiten der Heckschürze. Am Heck setzt ein neuer kraftvoll gestalteter Diffusor den Magnum Sport als Individualmodell von serienmäßigen Porsche Cayenne Fahrzeugen unübersehbar ab. Die Verbaubarkeit des Heckdiffusors in Verbindung mit Anhängenzugvorrichtung bleibt wie in allen TECHART Magnum Paketen auch beim neuen Sportmodell erhalten.

The TECHART Magnum Sport is the sport-focused variation of the TECHART Magnum. The special edition comes with an enhanced aerodynamic styling package which includes new carbon fiber parts.

A new dynamically shaped three-part front splitter and additional winglets inside the big air intakes at the front part attract attention at first sight. New carbon-made front wheel arch air outlets radiate a scent of motor sports and so do the two added carbon fiber air outlets at the rear of the Magnum Sport. A distinctively powerful rear diffuser visibly sets the TECHART Magnum apart from any series Porsche Cayenne model. As in all TECHART Magnum vehicles, the rear diffuser of the TECHART Magnum Sport can be detached to allow the optional towball to be deployed.







Im Detail: Die TECHART Magnum Frontverkleidung

- 1: TECHART Magnum Bugteil in eigenständigem Design
- 2: Montagevorbereitung für PAS Radarsensor
- 3: Abschlussblende Schlossträger
- 4: Luftführung Wasserkühler
- 5: Montagevorbereitung für Scheinwerferreinigungsanlage
- 6: TECHART Tagfahrlichtsystem
- 7: Airblades mit Lufteinlass und Aufnahme für TECHART Tagfahrlichtsystem
- 8: Frontgrill
- 9: Frontsplitter, 3-teilig
- 10: Unterbodenverkleidung mit Service-Öffnungen links und rechts
- 11: Lufteinlässe zur Bremsanlage
- 12: Nebelscheinwerfereinheit mit Aufnahme für Lufteinlass
- 13: Kühlluftführung zur Bremsanlage
- 14: Luftführung Ladeluftkühler
- 15: Montagevorbereitung für Positionsleuchten (US-Modelle)
- 16: Montagevorbereitung für Sensoren ParkAssistent
- 17: Radhausträger zur Montage an original Befestigungspunkten

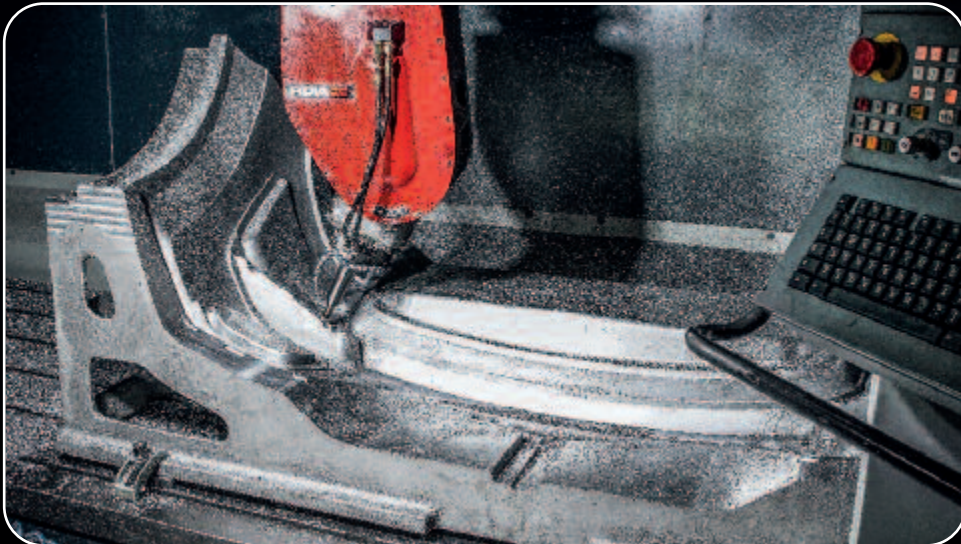

In Detail: The TECHART Magnum Front Apron

- 1: TECHART Magnum Front Apron, distinctive, powerful design
- 2: Mounting device for PAS radar sensor
- 3: Mounting cover trim
- 4: Water cooler air duct
- 5: Mounting device for headlight cleaning system
- 6: TECHART Daytime Running Light
- 7: Airblades with air intake and gear for TECHART Daytime Running Light
- 8: Central air intake grill
- 9: Front Splitter, 3-parts
- 10: Underfloor structure with integrated service lids left/right
- 11: Lower air intakes (brake system)
- 12: Auxiliary fog light unit with gear for lower air intake
- 13: Braking system air duct
- 14: Intercooler air duct
- 15: Mounting device for position lamps (US-vehicles)
- 16: Mounting device for ParkAssist sensors
- 17: Wheel arch mount, uses original mounting points

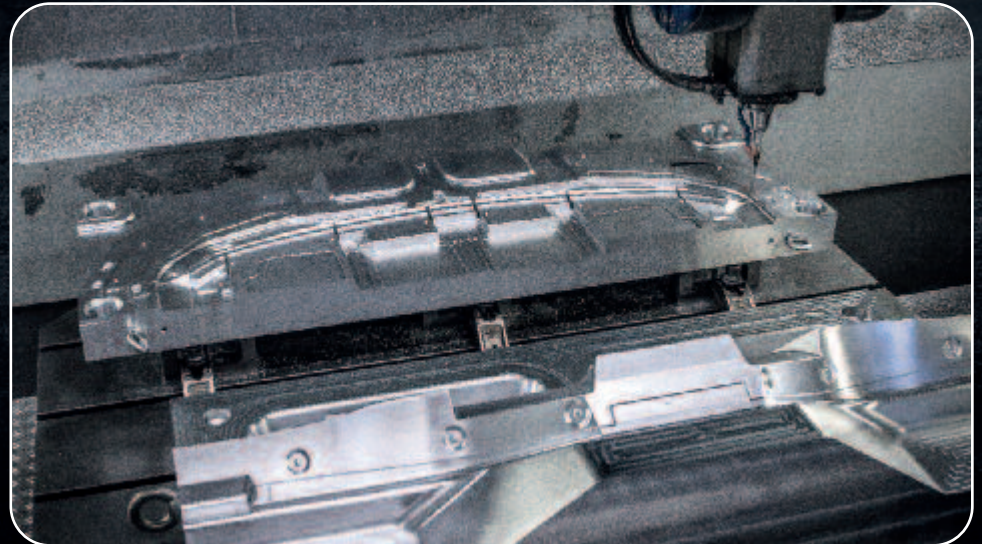

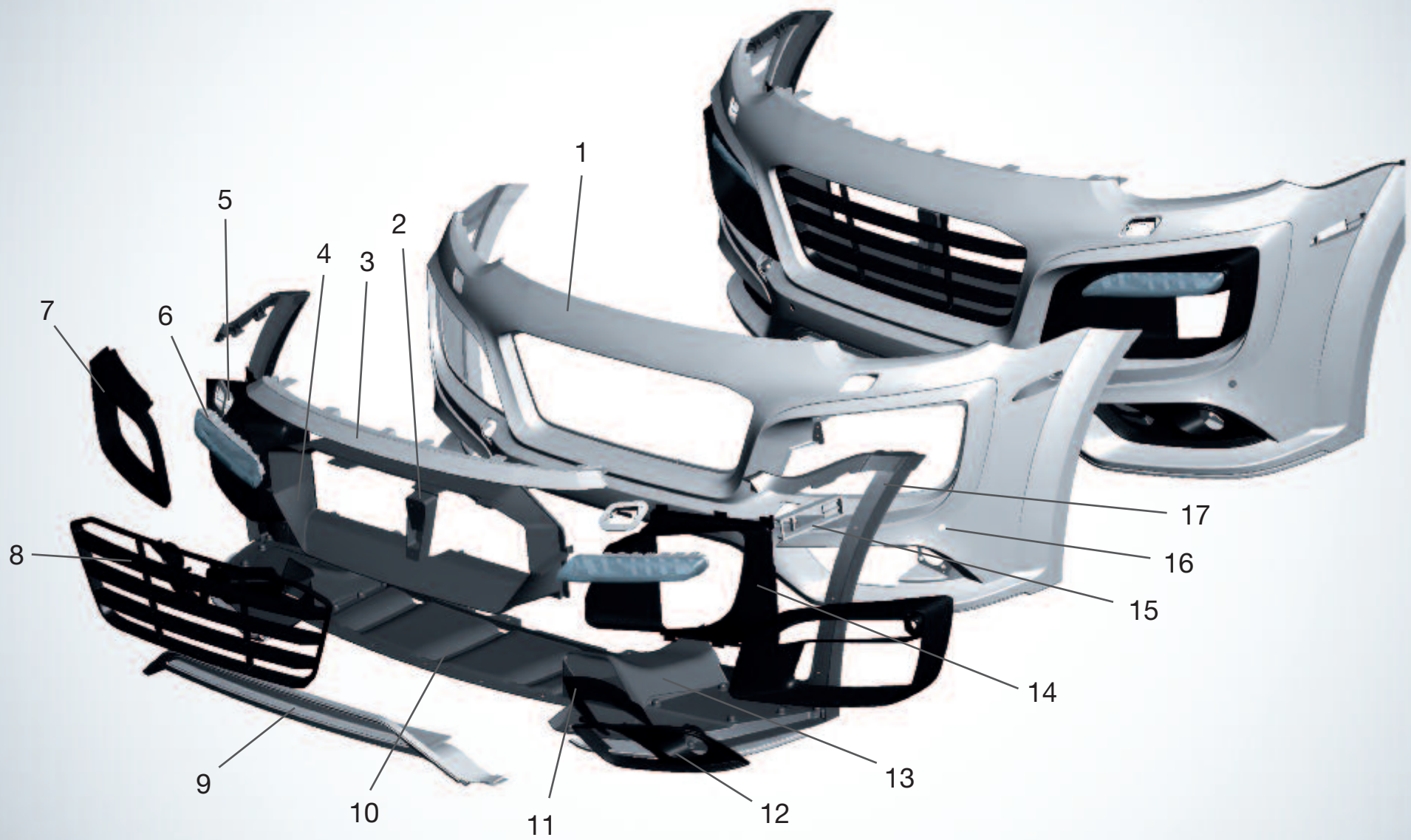



MAGNUM

D BBX 4800



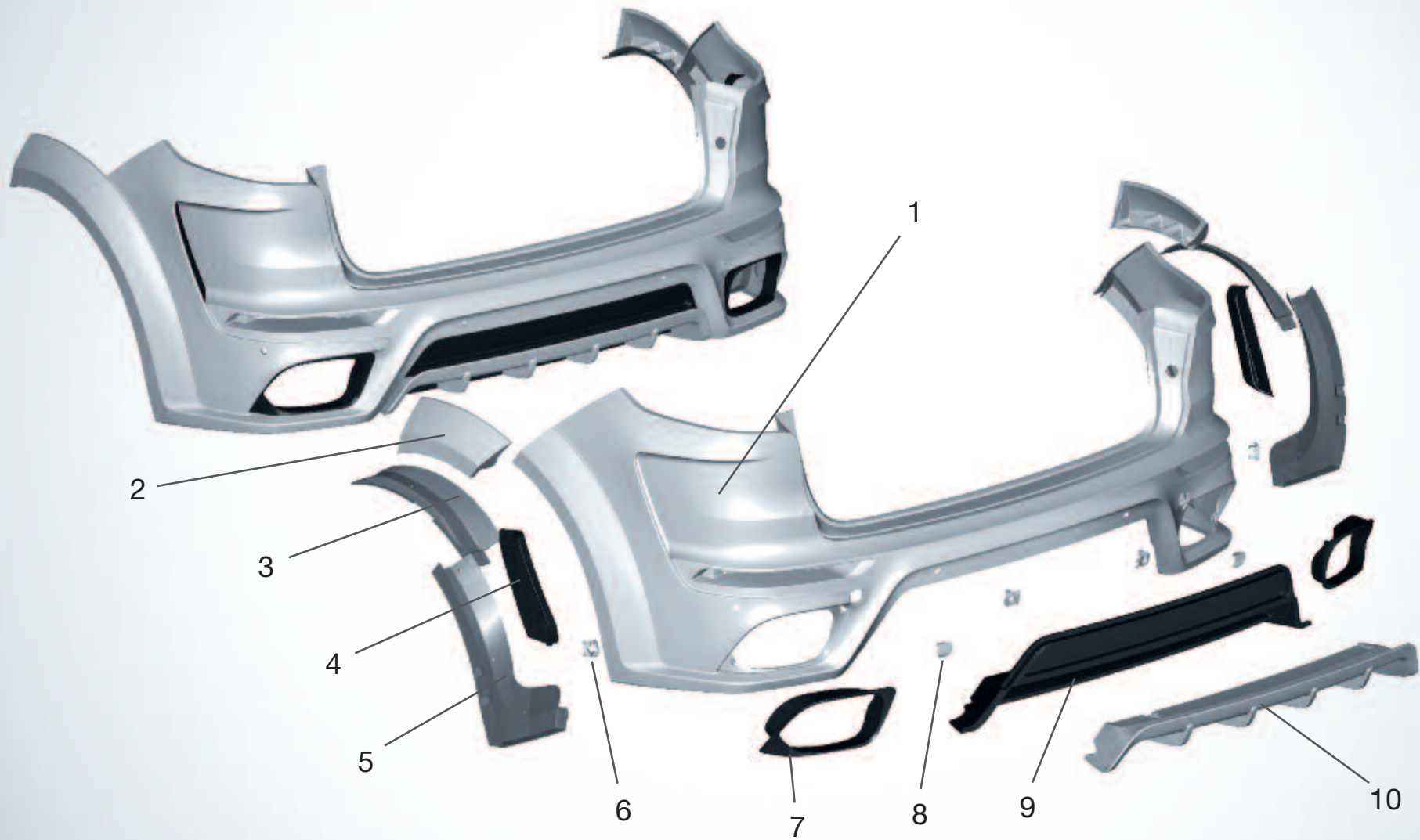

Im Detail: TECHART Magnum Heck- und Seitenverkleidungen

- | | |
|--|---|
| 1: TECHART Magnum Heckschürze, in eigenständigem Design | 10: Heckdiffusor. Abnehmbar für Fahrzeuge mit Anhängезugvorrichtung sowie mit elektronischer Sperre gegen Auslösen des elektrisch betätigten Kugelkopfs bei eingesetztem Diffusor |
| 2: Radhausverbreiterung Heckschürze | 11: Radhausverbreiterung mit Türflächenverkleidung hinten |
| 3: Träger Radhausverbreiterung | 12: Träger Radhausverbreiterung |
| 4: Zierelement Luftauslassoptik | 13: Zierleiste Fondtür |
| 5: Radhausträger zur Montage an original Befestigungspunkten | 14: Seitenschwellerverkleidung |
| 6: Montagevorbereitung für Sensoren ParkAssistent | 15: Türflächenverkleidung vorn |
| 7: Endrohrblende | 16: Zierleiste Vordertür |
| 8: Klappe für Abschlepphaken | 17: Radhausverbreiterung vorn |
| 9: Heckdiffusor-Rahmen | |

In Detail: TECHART Magnum Bodykit - Rear and Side

- | | |
|--|--|
| 1: TECHART Magnum Rear Apron, distinctive, powerful design | 10: Rear Diffusor. Detachable for vehicles with towbar system and equipped with safety locking system (prevents release of electrically deployed towball while diffuser is attached) |
| 2: Rear wheel arch extension | 11: Combined rear wheel arch extension and rear door panel |
| 3: Wheel arch extension mount | 12: Wheel arch extension mount |
| 4: Design trim air outlet element | 13: Rear door trim |
| 5: Wheel arch mount, uses original mounting points | 14: Side skirt panel |
| 6: Mounting device for ParkAssist sensors | 15: Front door panel |
| 7: Tailpipe design trim | 16: Front door trim |
| 8: Tow-hook lid | 17: Front wheel arch extension |
| 9: Rear diffuser surround | |







Motorleistung

Performance

<p>TECHART Motorleistungssteigerung TA 058/S1.1 + 30 kW (+ 40 PS), + 50 Nm</p> <p>Gesamtleistung: 354 kW (480 PS), 650 Nm</p> <p>Fahrleistungen: 0-100 km/h: 4,9 s, v_{\max}: 268 km/h</p>	<p>TECHART Engine Powerkit TA 058/S1.1 + 30 kW (+ 40 PS), + 50 Nm (+ 37 lb.-ft.)</p> <p>Total Power Output: 354 kW (480 hp), 650 Nm (479 lb.-ft.)</p> <p>Driving Performance: 0-100 km/h: 4.9 s, v_{\max}: 268 km/h</p>	058.300.485.009	<div style="display: flex; justify-content: space-between;"> <div style="width: 100%; height: 100%; background-color: white; border: 1px solid black;"></div> <div style="width: 100%; height: 100%; background-color: white; border: 1px solid black;"></div> <div style="width: 100%; height: 100%; background-color: white; border: 1px solid black;"></div> <div style="width: 100%; height: 100%; background-color: white; border: 1px solid black;"></div> <div style="width: 100%; height: 100%; background-color: white; border: 1px solid black;"></div> <div style="width: 100%; height: 100%; background-color: white; border: 1px solid black;"></div> <div style="width: 100%; height: 100%; background-color: white; border: 1px solid black;"></div> <div style="width: 100%; height: 100%; background-color: white; border: 1px solid black;"></div> </div>
<p>TECHART Motorleistungssteigerung TA 058/T1 + 59 kW (+ 80 PS), + 90 Nm</p> <p>Gesamtleistung: 441 kW (600 PS), 840 Nm</p> <p>Fahrleistungen: 0-100 km/h: 3,9 s, v_{\max}: 290 km/h</p>	<p>TECHART Engine Powerkit TA 058/T1 + 59 kW (+ 80 PS), + 90 Nm (+ 66 lb.-ft.)</p> <p>Total Power Output: 441 kW (600 hp), 840 Nm (620 lb.-ft.)</p> <p>Driving Performance: 0-100 km/h: 3.9 s, v_{\max}: 290 km/h</p>	058.300.590.009	<div style="display: flex; justify-content: space-between;"> <div style="width: 100%; height: 100%; background-color: white; border: 1px solid black;"></div> <div style="width: 100%; height: 100%; background-color: white; border: 1px solid black;"></div> <div style="width: 100%; height: 100%; background-color: white; border: 1px solid black;"></div> <div style="width: 100%; height: 100%; background-color: white; border: 1px solid black;"></div> <div style="width: 100%; height: 100%; background-color: white; border: 1px solid black;"></div> <div style="width: 100%; height: 100%; background-color: white; border: 1px solid black;"></div> <div style="width: 100%; height: 100%; background-color: white; border: 1px solid black;"></div> <div style="width: 100%; height: 100%; background-color: white; border: 1px solid black;"></div> </div>
<p>TECHART Motorleistungssteigerung TA 058/T2 + 132 kW (+ 180 PS), + 170 Nm</p> <p>Gesamtleistung: 514 kW (700 PS), 920 Nm</p> <p>Fahrleistungen: 0-100 km/h: 3,9 s, v_{\max}: 308 km/h</p>	<p>TECHART Engine Powerkit TA 058/T2 + 132 kW (+ 180 PS), + 170 Nm (+ 125 lb.-ft.)</p> <p>Total Power Output: 514 kW (700 hp), 920 Nm (679 lb.-ft.)</p> <p>Driving Performance: 0-100 km/h: 3.9 s, v_{\max}: 308 km/h</p>	058.300.720.009	<div style="display: flex; justify-content: space-between;"> <div style="width: 100%; height: 100%; background-color: white; border: 1px solid black;"></div> <div style="width: 100%; height: 100%; background-color: white; border: 1px solid black;"></div> <div style="width: 100%; height: 100%; background-color: white; border: 1px solid black;"></div> <div style="width: 100%; height: 100%; background-color: white; border: 1px solid black;"></div> <div style="width: 100%; height: 100%; background-color: white; border: 1px solid black;"></div> <div style="width: 100%; height: 100%; background-color: white; border: 1px solid black;"></div> <div style="width: 100%; height: 100%; background-color: white; border: 1px solid black;"></div> <div style="width: 100%; height: 100%; background-color: white; border: 1px solid black;"></div> </div>

¹ Nur für Cayenne Turbo.
¹ Only for Cayenne Turbo.

Cayenne
 Cayenne Diesel / S Diesel
 Cayenne S
 Cayenne S E-Hybrid
 Cayenne GTS
 Cayenne Turbo / Turbo S

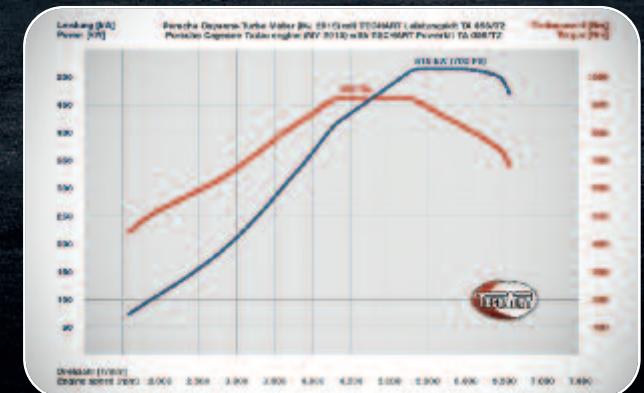



Motorleistung

Performance

<p>TECHART Motorleistungssteigerung TA 058/S1 + 59 kW (+ 80 PS), + 100 Nm</p> <p>Gesamtleistung: 368 kW (500 PS), 650 Nm</p> <p>Fahrleistungen: 0-100 km/h: 5,0 s, v_{max}: 276 km/h</p>	<p>TECHART Engine Powerkit TA 058/S1 + 59 kW (+ 80 PS), + 100 Nm (+ 74 lb.-ft.)</p> <p>Total Power Output: 368 kW (500 hp), 650 Nm (479 lb.-ft.)</p> <p>Driving Performance: 0-100 km/h: 5.0 s, v_{max}: 276 km/h</p>	058.300.500.009	<table border="1"> <tr><td></td><td></td><td></td><td>■</td><td></td><td></td><td></td><td></td><td></td><td></td></tr> </table>				■						
			■										
<p>TECHART Motorleistungssteigerung TA 058/D1 + 21 kW (+ 28 PS), + 40 Nm</p> <p>Gesamtleistung: 214 kW (290 PS), 620 Nm</p> <p>Fahrleistungen: 0-100 km/h: 7,0 s, v_{max}: 233 km/h</p>	<p>TECHART Engine Powerkit TA 058/D1 + 21 kW (+ 28 PS), + 40 Nm (+ 30 lb.-ft.)</p> <p>Total Power Output: 214 kW (290 hp), 620 Nm (457 lb.-ft.)</p> <p>Driving Performance: 0-100 km/h: 7.0 s, v_{max}: 233 km/h</p>	058.300.290.009	<table border="1"> <tr><td></td><td></td><td>²</td><td></td><td></td><td></td><td></td><td></td><td></td><td></td></tr> </table>			²							
		²											
<p>TECHART Motorleistungssteigerung TA 058/SD1 + 26 kW (+ 35 PS), + 100 Nm</p> <p>Gesamtleistung: 309 kW (420 PS), 950 Nm</p> <p>Fahrleistungen: 0-100 km/h: 5,2 s, v_{max}: 256 km/h</p>	<p>TECHART Engine Powerkit TA 058/SD1 + 26 kW (+ 35 PS), + 100 Nm (+ 74 lb.-ft.)</p> <p>Total Power Output: 309 kW (420 hp), 950 Nm (701 lb.-ft.)</p> <p>Driving Performance: 0-100 km/h: 5.2 s, v_{max}: 256 km/h</p>	058.300.431.009	<table border="1"> <tr><td></td><td></td><td>³</td><td></td><td></td><td></td><td></td><td></td><td></td><td></td></tr> </table>			³							
		³											

Cayenne
Cayenne Diesel / S Diesel
Cayenne S
Cayenne S E-Hybrid
Cayenne GTS
Cayenne Turbo / Turbo S

² Nur für Cayenne Diesel. ³ Nur für Cayenne S Diesel.
² Only for Cayenne Diesel. ³ Only for Cayenne S Diesel.

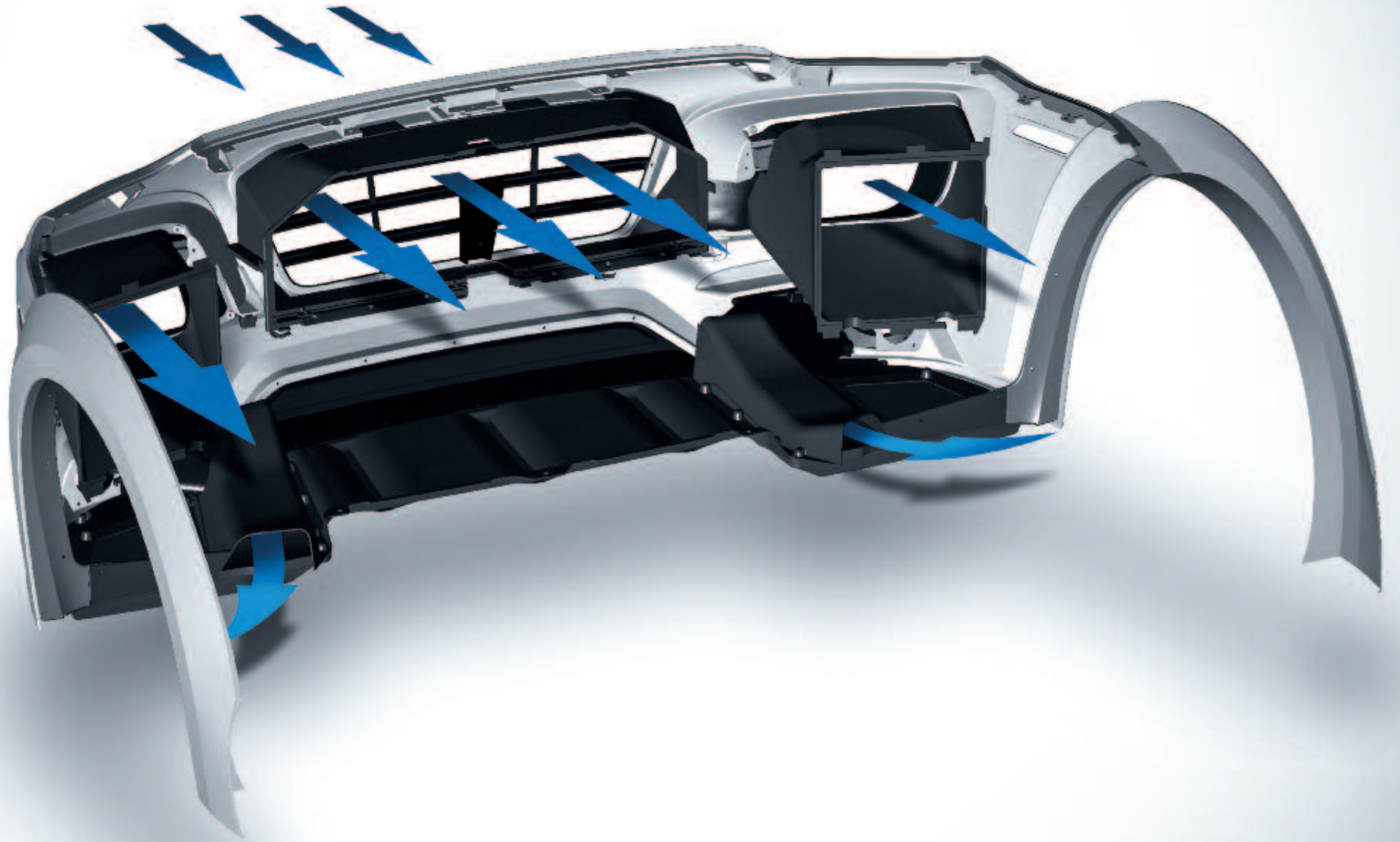



TURBO

TECHNIPOL
Arbeitsnummer: _____
Laufende Nr.: _____
Herstellungsjahr: _____
TURBOLADER
058.300.650.301
Zyl. 5-8









Hörproben

QR-Codes scannen oder
www.techart.de/action besuchen

Audio Samples

Scan the QR-Codes or
visit www.techart.de/action

Kopfhörer empfohlen
Headphones recommended

TECHART Abgasanlage »Sport«
für Cayenne Turbo S

Gasspiel & Wegfahrt [0:23]

TECHART Exhaust System »Sport«
for Cayenne Turbo S

Rev & Accelerate [0:23]



TECHART Abgasanlage »Sport«
für Cayenne Turbo S

Vorbeifahrten [0:30]

TECHART Exhaust System »Sport«
for Cayenne Turbo S

Drive-by [0:30]



TECHART Abgasanlage »Sport«
für Cayenne Turbo S

Fahrscene (onboard) [1:00]

TECHART Exhaust System »Sport«
for Cayenne Turbo S

Driving Scene (onboard) [1:00]



TECHART Abgasanlage »Sport«
mit TECHART Dynamic Sound
für Cayenne Diesel

Vergleich ohne/mit TDS [0:33]

TECHART Exhaust System »Sport«
with TECHART Dynamic Sound
for Cayenne Diesel

Comparison without/with TDS [0:33]



TECHART Abgasanlage »Sport«
mit TECHART Dynamic Sound
für Cayenne Diesel

Fahrscene (onboard) [1:07]

TECHART Exhaust System »Sport«
with TECHART Dynamic Sound
for Cayenne Diesel

Driving Scene (onboard) [1:07]





Abgasanlagen

Exhaust Systems

Cayenne
Cayenne Diesel / S Diesel
Cayenne S
Cayenne S E-Hybrid
Cayenne GTS
Cayenne Turbo / Turbo S

TECHART Abgasanlage »Sport«	TECHART Exhaust System »Sport«	058.310.891.009	<input type="checkbox"/>	<input type="checkbox"/>	<input type="checkbox"/>	<input type="checkbox"/>	<input type="checkbox"/>
TECHART Abgasanlage »Sport« mit TECHART Dynamic Sound	TECHART Exhaust System »Sport« mit TECHART Dynamic Sound	058.310.260.009 058.310.260.009	<input type="checkbox"/>	<input checked="" type="checkbox"/>	<input type="checkbox"/>	<input type="checkbox"/>	<input type="checkbox"/>
TECHART Sport-Endrohre in Kohlefaser matt mit Edelstahl-Innenrohr	TECHART Sport Tailpipes matt carbon fiber with stainless steel inner pipe	058.310.948.009	<input checked="" type="checkbox"/>	<input checked="" type="checkbox"/>	<input type="checkbox"/>	<input type="checkbox"/>	<input type="checkbox"/>
in Kohlefaser hochglänzend mit Edelstahl-Innenrohr	glossy carbon fiber with stainless steel inner pipe	058.310.949.009	<input checked="" type="checkbox"/>	<input checked="" type="checkbox"/>	<input type="checkbox"/>	<input type="checkbox"/>	<input type="checkbox"/>



¹ Nur für Cayenne Diesel. ² Nur für Cayenne S Diesel. ³ Für Cayenne V6 nur in Verbindung mit Porsche Sportabgasanlage ab Werk, Code OP8. ⁴ Für Cayenne Diesel nur in Verbindung mit TECHART Abgasanlage 058.310.260.009.
¹ Only for Cayenne Diesel. ² Only for Cayenne Diesel. ³ For Cayenne V6 only in conjunction with Porsche factory sports exhaust system, Code OP8. ⁴ For Cayenne Diesel only in conjunction with TECHART exhaust system 058.310.260.009.









Fahrwerk

Chassis

TECHART Luftfederungsmodul »Sport«

Um 22 mm tiefergelegtes Fahrwerk im Normalniveau gegenüber der herkömmlichen Luftfederung ab Werk sowie tieferes Beladungsniveau als im Serienmodell. Inklusive TECHART Sonderfunktion automatische Parkabsenkung bei Verriegelung des Fahrzeugs.

TECHART Air Suspension Module »Sport«

Normal Level ride height is lowered by 22 mm compared to the standard air suspension. The Loading Level is lower compared to the series model. The system includes the exclusive TECHART feature Automatic Parking Level, which lowers the vehicle at front and rear when the car is locked.

058.200.285.009

Cayenne
Cayenne Diesel / S Diesel
Cayenne S
Cayenne S E-Hybrid
Cayenne GTS
Cayenne Turbo / Turbo S

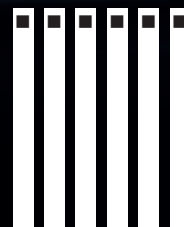

TECHART Formula



TECHART Formula III



TECHART Formula II



TECHART Formula IV

Räder

Wheels

Cayenne
 Cayenne Diesel / S Diesel
 Cayenne S
 Cayenne S E-Hybrid
 Cayenne GTS
 Cayenne Turbo / Turbo S

<p>TECHART Formula Leichtmetallrad</p> <p>Fünf Speichen Rad. Besonders elegantes, klassisches Design, erhältlich in 20- bis 23-Zoll. Varianten: Shiny Silber, Schwarz hochglänzend oder Ausführung Individual.</p>	<p>TECHART Formula Wheel</p> <p>Five Spokes Wheel. A renowned and elegant design classic, available in 20- to 23-inch. Diversity: Shiny Silver, Gloss Black or Individual Color Match</p>	<p>[...].210.[...].[...]</p>	<p>█ █ █ █ █ █</p>
<p>TECHART Formula II Leichtmetallrad</p> <p>Fünf Speichen Rad in mehrteiliger Optik sowie mit austauschbarem Edelstahl-Anfahrschutz. Erhältlich in 22- und 23-Zoll. Varianten: Shiny Silber, Schwarz hochglänzend oder Ausführung Individual.</p>	<p>TECHART Formula II Wheel</p> <p>Five Spokes Wheel in multi-part look with exchangeable stainless steel wheel protection hump. Available in 22- and 23-inch. Diversity: Shiny Silver, Gloss Black or Individual Color Match.</p>	<p>[...].212.[...].[...]</p>	<p>█ █ █ █ █ █</p>
<p>TECHART Formula III Schmiederad</p> <p>Doppelspeichen Schmiederad mit besonders geringem Eigengewicht. Erhältlich in 21- und 22-Zoll. Varianten: Sterling Silber oder Ausführung Individual.</p>	<p>TECHART Formula III Forged Wheel</p> <p>Particularly low weight Twin Spokes Wheel. Available in 21- and 22-inch. Diversity: Sterling Silver or Individual Color Match.</p>	<p>055.215.[...].[...]</p>	<p>█ █ █ █ █ █</p>
<p>TECHART Formula IV Leichtmetallrad</p> <p>Doppelspeichen Rad mit besonders geringem Eigengewicht. Erhältlich in 22-Zoll. Varianten: Bicolor Grau/glanzgedreht, Bicolor Schwarz/glanzgedreht oder Ausführung Individual.</p>	<p>TECHART Formula IV Wheel</p> <p>Particularly low weight Twin Spokes Wheel. Available in 22-inch. Diversity: in Bi-Color Grey/Gloss Turned, Bi-Color Black/Gloss Turned or Individual Color Match.</p>	<p>058.214.105.[...]</p>	<p>█ █ █ █ █ █</p>





Interieur

Interior

TECHART 3-Speichen Sportlenkrad TECHART 3-spokes sport steering wheel

B95.430.376.CCC

Ergonomisch geformt, Bezug in Individualfarbe aus Leder mit handgefertigter Ziernaht. Passend für Serien-Airbageinheit

Ergonomic shape, made of fine leather in custom color with hand sewed stitching. Fits the series airbag unit

TECHART Exklusiv Lederausstattung

TECHART Exclusive Leather Interior

058.407.060.000

Manufaktur-Interieur in TECHART Design mit Einzelsitzanlage und Mittelkonsole im Fond. Sitze mit Soft-Comfort Polsterung, im Fond mit Komfort-Kissen in Leder.

Handcrafted TECHART Design Interior with rear single seats unit and rear center console. All seats feature a Soft-Comfort upholstery, rear seats include two cozy leather pillows.

Lederausstattungsumfang: Armaturenbrett Ober- und Unterteile, Kombiinstrument, Mittelkonsoleneinheit, Airbag, Türverkleidungen, Türgriffe, Zierblenden, Armlehnen, Sitze inkl. Verblendungen, A-/B-/C-/D-Säulenverkleidungen, Dachhimmel (Alcantara), Sonnenblenden, Gepäckraum, Heckklappenverkleidungen, Gepäckraumabdeckung, Fußraum in Leder-/Teppichkombination, Fußmatten mit Softpolsterung und Ledereinfassung, Gepäckraummatte mit Ledereinfassung.

Leather Interior: upper and lower dashboard unit, instrument cluster, center console unit, Airbag, door panels, door handles, trim panels, armrests, seats including trims and panels, interior A-/B-/C- and D-pillar covering, roof liner (Alcantara), sun visors, luggage compartment, rear hatch covering, luggage compartment cover, flooring in leather-/carpet combination, floor mats with comfort upholstery and leather edging, luggage compartment mat with leather edging.

TECHART Carbon-Line Interieur

TECHART Carbon Line Interior

058.421.[...]

Zierteilepakete für Armaturentafel, Türen und Mittelkonsole. Erhältlich in Farbe Graphit oder in Wunschfarbe sowie in Sonderausführung Carbonstruktur mit Akzentfarbe.

Interior Trim Package for dashboard, doors and center console. Available colors: Graphite, Custom Color and special carbon fiber texture with contrast color.

Carbon Graphite/Carbon Graphite matt
Carbon Individual

Carbon Graphite/Carbon Graphite matt
Carbon Individual

Carbon Red Graphite/Carbon Red Graphite matt

Carbon Red Graphite/Carbon Red Graphite matt

Carbon Blue Graphite/Carbon Blue Graphite matt

Carbon Blue Graphite/Carbon Blue Graphite matt

Cayenne
Cayenne Diesel / S Diesel
Cayenne S
Cayenne S E-Hybrid
Cayenne GTS
Cayenne Turbo / Turbo S

<input type="checkbox"/>	<input type="checkbox"/>	<input type="checkbox"/>	<input type="checkbox"/>	<input type="checkbox"/>	<input type="checkbox"/>
<input type="checkbox"/>	<input type="checkbox"/>	<input type="checkbox"/>	<input type="checkbox"/>	<input type="checkbox"/>	<input type="checkbox"/>
<input type="checkbox"/>	<input type="checkbox"/>	<input type="checkbox"/>	<input type="checkbox"/>	<input type="checkbox"/>	<input type="checkbox"/>
<input type="checkbox"/>	<input type="checkbox"/>	<input type="checkbox"/>	<input type="checkbox"/>	<input type="checkbox"/>	<input type="checkbox"/>

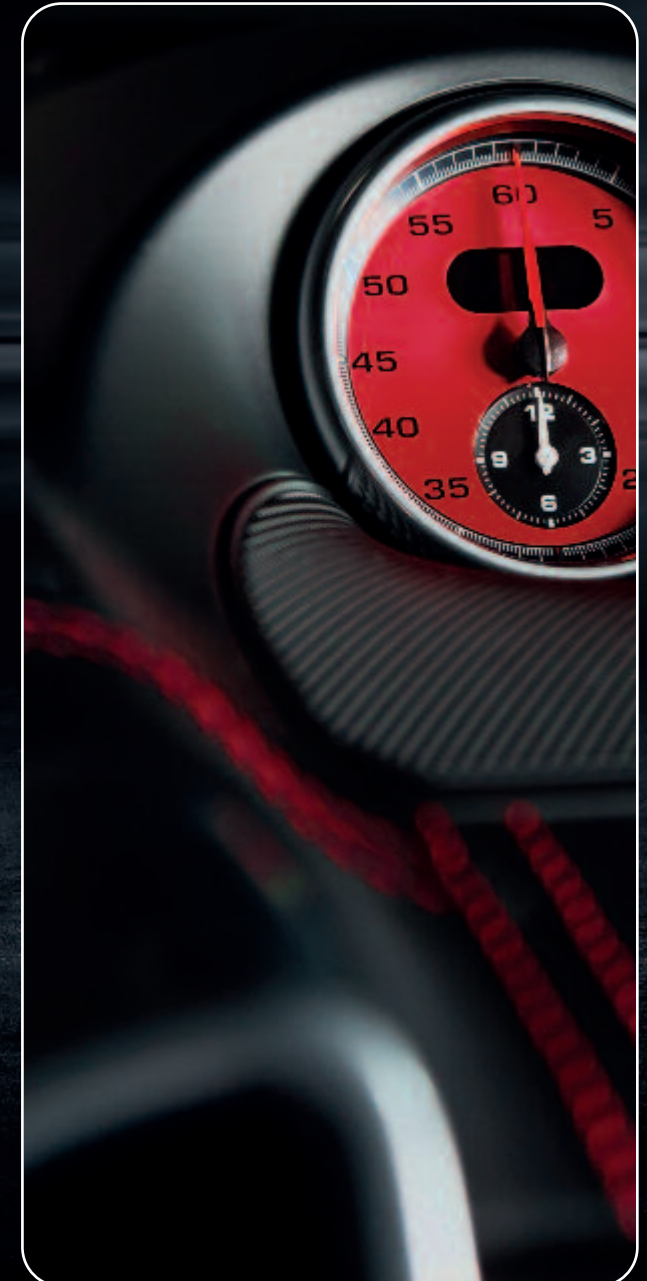







Interieur

Interior

TECHART-Interieur »Magnum Sport«

Interieurbereiche in Leder mit TECHART-Farbziernaht (3-fach - Design)

Ausstattungsumfang:

Armaturenbrettober-/ -unterteil, Rahmen Kombiinstrument oben/unten, Mittelkonsoleneinheit komplett, Türverkleidungen vorn/hinten, Türgriffe, Blenden, Armlehnen, Sonnenblenden, Dachgriffe., Sitze vorn / hinten in MAGNUM Sport Design, Sitzmitteldesign mit Perforation, Rahmenbiesen, Alcantarabesatz, Prägelogo MAGNUM Sport, Sitzverblendungen, A/B/C/D-Holmverkleidungen, Dachhimmel, Türeinstieg-Verkleidungen, Gepäckraum- & Heckklappenverblendungen, Kofferraumabdeckung (Rollo), Fußmatten vorn/hinten in MAGNUM Sport Design mit Ledereinfassung, Kofferraummatte mit Ledereinfassung.

TECHART-Interior »Magnum Sport«

Interior areas in leather with TECHART colored decorative stitching (triple design).

Features:

Dashboard upper / lower part, instrument cluster top & bottom, complete center console unit, front and rear door panels, door handles and trims, arm rests, sun visors, roof grab handles, front and rear seats in MAGNUM Sport Design, seat center design with perforation, frame cords, alcantara trims, embossed MAGNUM Sport logo, seat panels, A/B/C/D-column covers, roof liner, door entry trims, luggage compartment and tailgate covers, luggage compartment cover (roller blind), front and rear floor mats in MAGNUM Sport Design with leather edging, luggage compartment mat with leather edging.

058.407.070.000

Cayenne
Cayenne Diesel / S Diesel
Cayenne S
Cayenne S E-Hybrid
Cayenne GTS
Cayenne Turbo / Turbo S

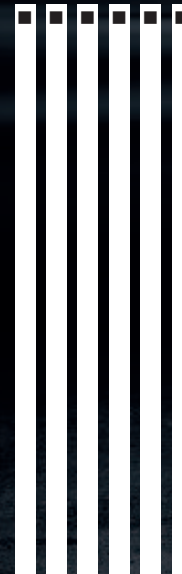

Das Sondermodell Magnum Sport verfügt über eine von der TECHART Interieurmanufaktur geschmackvoll abgestimmte Innenausstattung mit wertvollsten Werkstoffen. Die handgefertigte Lederausstattung mit einer Kombination aus Leder und Alcantara® wird durch Kohlefaser- und Lackoberflächen vervollständigt. Die Sitzflächen sind vorne wie hinten in Magnum Sport Sonderdesign ausgeführt. Individuelle Instrumenten- und Sport Chrono Zifferblätter sowie abgesetzte Ziernähte setzen farbliche Akzente. Das ergonomische TECHART 3-Speichen Sportlenkrad bietet dem Fahrer volle Kontrolle und umfangreiche Individualisierungsmöglichkeiten.

The Edition Magnum Sport has a handcrafted interior with precious materials, tastefully composed by the TECHART Interior Manufactory. The combination of leather and Alcantara® is completed by lacquered details and carbon fiber. The center seat areas are finished in the attractive Magnum Sport design. Individual instrument and Sport Chrono dials as well as decorative stitchings, set selective color-highlights. The ergonomic TECHART three-spokes sport steering wheel makes the driver feel comfortable and offers comprehensive individualization options.







MAGNUM
Sport

TECHART
AUTOMOBILDDESIGN

TECHART

www.techart.de

TECHART







TECHART Automobildesign GmbH
Röntgenstraße 47, 71229 Leonberg, Germany

Tel. +49 (0)7152 9339-0, Fax +49 (0)7152 9339-33, E-Mail info@techart.de, <http://www.techart.de>

Änderungen und Irrtümer vorbehalten. Subject to change without notice.

058.991.119.003-03, 03/2018

Copyright by TECHART Automobildesign GmbH

Broschüre herunterladen



Download brochure